



LEAK STOP+ by DynaQuip®

Owner's Manual and Installation Guide



The proven leader in household leak protection: **WaterCop®** is there when you're not.

Quick Start

1. Select installation location of valve, just upstream from inlet of water appliance making sure the sensors can reach the ground
2. Using compression or solder fittings, install brass valve into inlet pipe
3. Mount **Leak Stop+** control box on valve (see page 4)
4. Apply power to **Leak Stop+** control box
5. Place sensors in areas where water would begin to accumulate
6. Test and restore to ready status
7. Please read entire manual and save for future maintenance reference

System Overview

WaterCop® **Leak Stop+** detects water leaks in your plumbing system at a single location and automatically shuts off the water supply to that same location. Early leak detection coupled with automatic water shut-off is the best way to prevent extensive water damage.

Support and Assistance

Contact DynaQuip Controls for technical support and installation assistance:
Toll-free: 1-800-545-3636 (M-F, 8 AM-5 PM Central Time)
email: info@dynaquip.com

General Safety Information

WARNING:

- Do not apply electrical power to the unit unless the unit is fully assembled (as it shipped). Failure to do so could result in personal injury and/or damage to the unit.
- Disconnect power source before working on or servicing the unit. Failure to do so could result in personal injury.
- **Leak Stop+** must be installed indoors. The ambient air temperature of the **Leak Stop+** should be between 35° F and 105° F. Do not expose the **Leak Stop+** to freezing temperatures or extreme heat.

- The valve closes with great force. It could cut off a finger. Keep fingers and other items out of the valve when testing.
- The WaterCop® **Leak Stop+** case is NOT EXPLOSION PROOF. The shut-off valve must NOT be installed where it could ignite flammable vapors or explosive mixtures.

IMPORTANT:

- Adherence to all local and municipal building, plumbing, and electrical codes as they pertain to the installation of the WaterCop® **Leak Stop+** system is of utmost importance. Codes in some areas may require that a licensed plumber be employed to do the installation, or that the proper permits be obtained prior to any installation. Even if local codes do not require a licensed plumber to do the installation, it is necessary that the installer has a professional level of competence in both plumbing and electrical skills to perform the installation. These instructions assume this level of knowledge and skill. If in doubt, use a licensed professional.
- Check with original appliance manufacturer for instructions regarding the special servicing of water heater (or other water bearing appliance) when inlet water supply is stopped for any reason or length of time.

CAUTION:

It is strongly recommended that eye protection be worn while servicing the system. Failure to do so could result in personal injury.

WARNING:

To reduce risk of electrical shock, fire, or damage to property or WaterCop®:

- 1. Use a common, 120 VAC outlet.** Use of a surge protector is recommended.
- 2. Do not use extension cords**
 - Use of extension cords can cause fires or electric shock.
 - Install WaterCop® **Leak Stop+** within reach of an existing outlet.
 - Install an outlet near the **Leak Stop+**. Comply with all local codes.
- 3. Before opening case, unplug power cord.** When the case is open, it is possible to contact electrified components. Always unplug the power cord before opening the unit.

System Components

WaterCop® **Leak Stop+** consists of two components which may be purchased together or individually.

1. The **Leak Stop+** brass valve sized to the same diameter as the existing supply line. ANSI/NSF 372 approved full flow, forged brass 400psi CWP.
2. The **Leak Stop+** electric control box with attached moisture sensors.
 - 12 VDC includes 120 VAC adapter
 - 2 (two) moisture sensors with 10' (ten foot) cords.

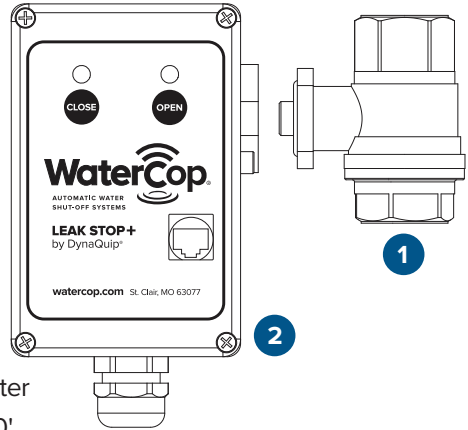

Optional Parts and Accessories

Leak Stop+ optional accessories and limited repair parts are available by calling customer service at 800-545-3636.

SmartConnect

- 24/7 control and access to your LeakStop + through the WaterCop app
- Mobile alerts about automatic closure and power outages
- Wi-Fi compatible

RS100 Wall Switch

- Convenient water shut-off from a wall mounted control panel
- Color coded LED valve position indicator lights

Repair parts include:

- The complete **Leak Stop+** control box
- Replacement brass ball valve
- Sensor cord and probe (if damaged). The maximum number of sensors the **Leak Stop+** is capable of supporting is 2 (two).

Installation Location

The WaterCop® **Leak Stop+** must be installed indoors and directly into the plumbing supply line, just upstream of the appliance or area you wish to monitor and protect. **Leak Stop+** requires 120 VAC power to operate. Verify location of an outlet within easy reach of the **Leak Stop+** unit. The attached leak sensor will be secured to the floor or catch pan where water would first accumulate if a leak occurs. The most common area of installation would be a water heater as illustrated here:

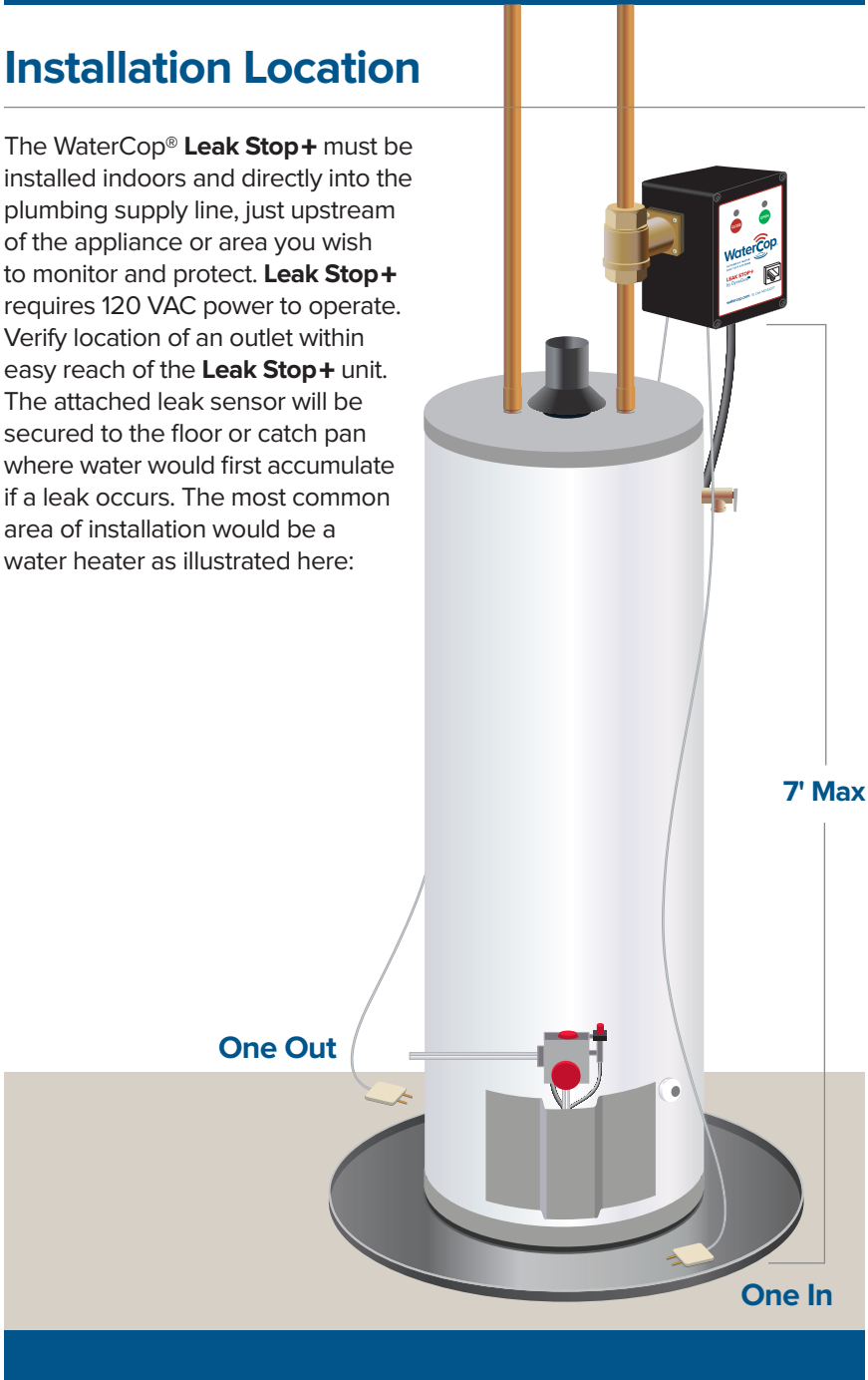

Installation Guidelines

Review all Safety Guidelines listed on page 3.

Use of a licensed, professional plumber is highly recommended and may be required in some municipalities.

1. Separate the brass valve from the control box by removing the spring clip and O-ring. **RETAIN THIS CLIP AND O-RING.**
2. Using compression fittings or sweat fitting adaptors, install the properly sized brass valve into the plumbing system, just upstream from the device on the cold water supply. Orient the valve in such a way that when the **Leak Stop+** control box is properly attached, the homeowner will have easy access to the open/close buttons. **Leak Stop+** requires 120 V outlet to operate.
3. Verify that the valve and the Leak Stop motor are both in the **OPEN** position.
 - The slot in the valve stem should be in line with the valve body, end to end. The valve will be open.
 - Apply power to the control box by plugging it into 120 VAC. The green light should be **ON**. If not, press the green button and the unit will cycle to the **OPEN** position. DISCONNECT POWER.

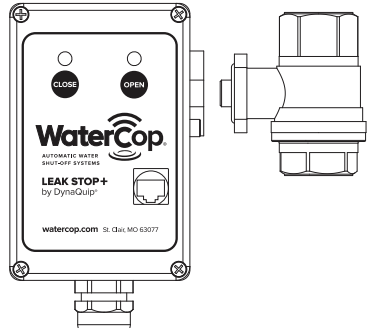

4. Install O-ring in the valve flange. Mount the **Leak Stop+** motor onto the valve and secure with the spring clip provided. **IMPORTANT:** The control box **MUST** be aligned with the valve as shown. Verify the spring clip is firmly seated at all corners.
5. Plug in the unit to the selected nearby 120 V outlet.

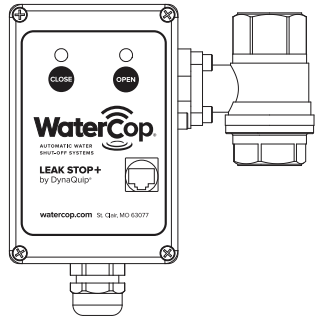

Sensor Placement

Place the attached sensor probes in the areas where water would first accumulate if a leak occurs.

Note: Care should be taken to place the sensor probe flat on the floor so water can be detected as soon as it begins to accumulate. The gold pins should not come in contact with any other objects or the flooring surface.

Sensors should be taped or adhered directly to the floor or pan under the monitored appliance, however extreme care should be taken to avoid:

1. tape or adhesive touching or hindering water reaching the gold pins;
2. the gold pins do not come into contact with metal or other conductive services.

This may cause a false alarm of the system.

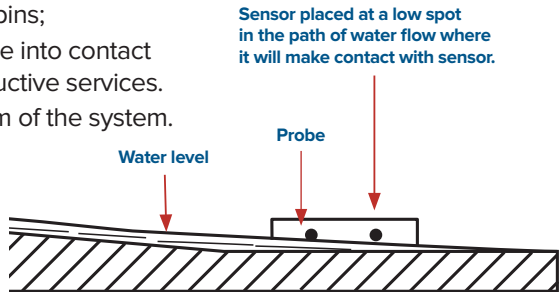

System Operation

The WaterCop® **Leak Stop+** constantly monitors the selected area for accumulating moisture. When water comes in contact with the sensor probe, the **Leak Stop+** control box will close the valve, shutting off the local water supply. The valve will remain closed until it is manually reset using the green button on the **Leak Stop+** control box, wall switch, or through the SmartConnect app. Lights on the **Leak Stop+** control box also indicate valve position (Red = Closed, Green = Open).

The WaterCop® **Leak Stop+** valve may be controlled independent of a water leak event using the open/close buttons on the front of the actuator.

The WaterCop® **Leak Stop+** requires an uninterrupted standard 120 VAC household outlet. In the event of power failure, the **Leak Stop+** valve will remain in current position. When power is restored, the valve remains in current position.

Operating Instructions

Leak Stop+ is capable of providing two alarm relay connections (dry contact closures or 12 VDC signal) to report current valve position. When water is detected by one of the sensors; the valve will close, the audible alarm will sound, the indicator lights will display **CLOSED**, and the alarm relays will activate. An auxiliary powered device, such as buzzer, lights, alarm, etc., can be triggered from this output signal. See drawing below for wiring instructions.

SELECT DRY CONTACT OR 12VDC

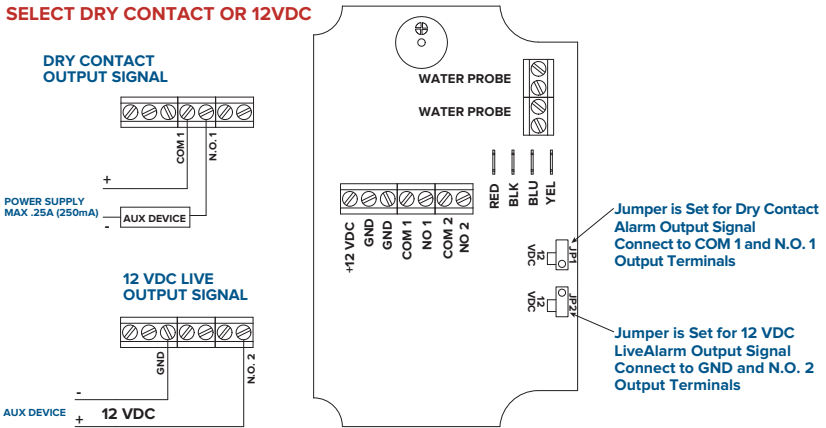

RELAY WIRING TO TERMINATE POWER

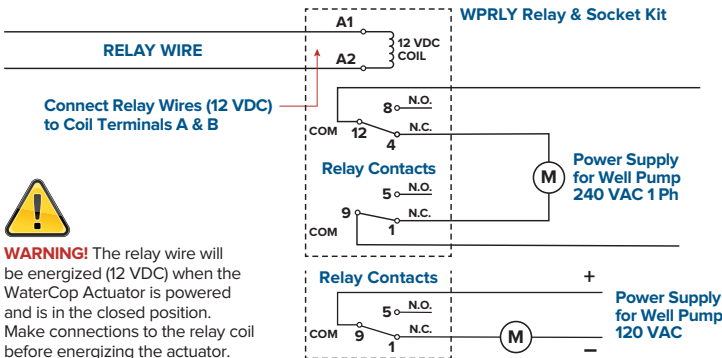

To silence the alarm, press one of the buttons on the face of the actuator. After the leak is repaired, press the open button, the valve will open and the system will return to normal.

Initial and Periodic Testing of the System

It is important that initial and quarterly testing testing of the system be conducted to ensure continued protection against sudden and accidental plumbing flooding.

Maintenance Procedure: Approx. _____ min./mo.

1. Verify that the **Leak Stop+** valve is plugged into a standard grounded outlet and powered up.
2. Verify the **Leak Stop+** valve is in the **OPEN** position (GREEN light illuminated).
3. Using a wet cloth, so as to not disturb adhesive (do not use distilled or RO water), saturate sensor to activate valve closure.
4. The sensor will detect the water and the **Leak Stop+** valve will cycle to the **CLOSED** position.
5. Verify the **Leak Stop+** valve is in the **CLOSED** position (RED light illuminated).
 - If **Leak Stop+** is installed on a water heater, you can additionally test closure of the valve by then opening any downstream hot water faucet in the home as if you were drawing hot water. As the residual water in the pipe runs out, you will notice a slowing of flow and finally a stoppage of water. **YOU MUST TEST A HOT WATER FAUCET.** Testing a cold water faucet will not return an accurate result.
 - If **Leak Stop+** is installed on any other water appliance, verify that outlet flow has stopped by attempting to draw water from that device.
6. Remove the sensor from the water and dry thoroughly. Remember to close any dry faucets you may have opened during testing.
7. Press the GREEN button on the **Leak Stop+** control panel to open the valve and restore water supply.
8. Repeat steps 2 through 7 for the second sensor.
9. Test buttons.

Troubleshooting

Leak sensor does not detect water.

1. Verify the **Leak Stop+** is receiving power.
2. Verify the gold prongs are making continued and direct contact with water.
3. If testing, verify tap water is being used rather than distilled or RO water.

Leak Stop+ RED or GREEN light does not illuminate

Verify the **Leak Stop+** is plugged into a grounded 120VAC household outlet and that outlet is powered.

Leak Stop+ motor does not close or open the valve correctly.

1. Verify the **Leak Stop+** is plugged into a grounded 120VAC household outlet and that outlet is powered.
2. Verify the valve is correctly orientated to the control box. See page 6 (Installation Guidelines No. 4).
3. If the brass valve has a solder connection, verify that the ball valve seats were not damaged by excessive heat.
 - A. Remove the **Leak Stop+** control box (retain the O-ring and spring clip for later re-attachment).
 - B. Using a flat-headed screwdriver, gently but firmly turn the ball valve stem open and closed to move the ball. The flat-headed screw driver will fit into the slot of the ball stem and you will be able to move the position of the valve manually.
 - C. Verify that the ball inside the ball valve can move. The ball will not be completely loose, but you will be able to rotate it with slightly moderate pressure.
 - D. Return the ball stem back to the original position so that it will line up with the drive of the actuator. The stem slot should be perpendicular to the length of the valve and in-line with the pipe.
4. If the brass valve has a compression fitting connection, verify the compression fittings were not over tightened causing damage to the valve, seal or seat.
 - A. Remove the **Leak Stop+** control box (retain the O-ring and spring clip for later re-attachment).
 - B. Using a flat-headed screwdriver, gently but firmly turn the ball valve stem open and closed to move the ball. The flat-headed screw driver will fit into the slot of the ball stem and you will be able to move the position of the valve manually.
 - C. Verify that the ball inside the ball valve can move. The ball will not be completely loose, but you will be able to rotate it with slightly moderate pressure.
 - D. Return the ball stem back to the original position so that it will line up with the drive of the actuator. The stem slot should be perpendicular to the length of the valve and in-line with the pipe.
5. If the valve does not complete the rotation due to blockage in the valve, the unit will go into the ALARM state. Both lights will flash, alarm will sound and the alarm relay will activate. To silence the alarm, press one of the buttons on the face of the actuator. Refer to Troubleshooting section 4 for valve troubleshooting.

Limitations of the System

While this is an advanced design automatic water shut-off system, it does not offer guaranteed protection against sudden or accidental discharge of water from a plumbing system. Any automatic water shut-off system, whether commercial or residential, is subject to compromise or failure to warn or activate for a variety of reasons. For example:

- Water intrusion from sources external to the plumbing supply system such as; rain, hurricane, storm water, sewer back-up, swimming pools, spas, thawing snow and ice, ice dams, HVAC condensation, freezer defrosting, etc.
- Water shut-off valves, water intrusion detectors and sensors, and many other sensing devices will not work without power. Battery operated devices will not work without batteries, with dead or insufficiently charged batteries, or if the batteries are not installed properly. Devices powered solely by AC power will not function properly if their AC power supply is interrupted, however briefly, or cut off for any reason.
- Sudden and accidental water leaks from plumbing systems can occur at anytime and at any point in the supply line system. Leaks that occur in areas not immediately monitored by or in very close proximity to an active water leak sensor may not be quickly detected or may not be detected at all by the leak detection system.
- This equipment, like other electrical devices, is subject to component failure. Even though this equipment is tested at the factory prior to shipment and designed to last as long as 10 years when properly maintained, the electronic components could fail at any time.
- As with other electrical devices, power surges or spikes can cause circuitry to malfunction or fail. Proper surge protection is necessary to avoid potential damage to the electronics of this system.
- The automatic valve is designed to provide positive shut-off of the plumbing water supply when connected to live AC power. However if the valve becomes corroded or blocked due to normal sediment or other internal water line material build-up, the valve may not function properly when needed.

The most common reason an automatic water shut-off system fails to perform when needed is due to inadequate maintenance. DynaQuip Controls recommends this system be tested monthly to make sure the automatic valve and both sensors are working properly.

Installing an automatic water shut-off system may qualify a homeowner for lower insurance premiums or a one-time credit. An automatic water shut-off system is not a substitute for adequate insurance or proper home maintenance. Homeowners, property owners, and renters should be proactive in protecting their property from sudden and accidental water loss and continue to adequately insure their property against common forms of damage.

Visit WaterCop.com for your warranty information.



LEAK STOP+ by DynaQuip®



To order or for additional information, visit watercop.com or call **800-545-3636**.